

An Intelligent Anti-Collision System for Electric Vehicles Applications

Ikenna Chinazaekpere IJEH¹ and Mahmoud SHAFIK¹
*University of Derby, College of Engineering & Technology,
Derbyshire DE22 3AW, UK*

Abstract. This paper presents the initial outcomes of the ongoing research to develop an intelligent online fault monitoring and anti-collision system for electric vehicle industrial applications. This is aiming to utilise the latest development in sensors technology and multi-level of redundancy approach, to improve the safety of electric vehicle and minimize the risk of road collision. This paper is focused on the development of the anti-collision system. The system is a network of sensors utilising the near real time embedded system. Four operational conditions were considered and some activities have been taken to control the speed and steering control system of the vehicle at an imminent collision. Visual alerts using LEDs were developed to indicate vehicles or obstacles along the path of the host vehicle even at an opposite direction. The proposed system was tested indoor using off-shelf mini vehicle model and further field test have been planned to ensure the operability of the system in relevant applications. Research is still undertaken to develop the online fault detection, monitoring and online recovery tolerance system using multi-level of redundancy and a hot-standby dual control unit.

Keywords: Electric Vehicles, Electric Vehicles Safety, Fault Detection.

1. Introduction

The automobile industry is evolving fast and end-user expectation is far beyond what have been realised. Recent development in the industry has been to rework the control systems of the basic functions of a vehicle (acceleration, de- acceleration, braking and steering) which performed by mechanical or hydraulic systems to more suitable, flexible and reliable electrical/electronic (E/E) systems. This is aiming to adopt the electric technology, improve the energy efficiency, reduce the parts and weight of a vehicle and possibly the overall cost [1]. The concept design is to replace the complicated Mechanical/Hydraulic system to drive-by-wire technology which is a stimulation from the fly-by-wire technology. Drive-by-wire (DBW) or X-by-wire technology comprises of three basic systems: steer-by-wire (SBW), brake-by-wire (BBW) and throttle-by-wire (TBW) and others being shift-by-wire and park-by-wire.

In the 1980 - the throttle-by-wire - series of Chevrolet Corvette was one of the initial implemented model [2]. The use of DBW technology tends to improve signal flow and efficient interconnection between different E/E systems in the car. It also easing the use of intelligent safety and control functions such as; anti-lock brake

¹ Corresponding Author. ijeh1@unimail.derby.ac.uk & m.shafik@derby.ac.uk

system, vehicle stability control system, rollover prevention assistance, collision avoidance, driver-less vehicles. This is in addition to other possible related innovations which would not have been feasible, reliable or efficient with a mechanical or hydraulic control system in use [3].

2. State-of-the-Art of Electric Vehicles Technology

The emergence of the DBW vehicles technology have some safety concerns from manufacturers, end-users and regulatory bodies. This has been an obstacle to the introduction of the technology globally. Nissan's latest design of the SBW control system in high-end vehicles was with the intent for direct handling, straight-line stability and a high sense of security with a conventional steering as backup. The steering system comprises of a camera and processing module, electric control unit, clutch, steering force actuator and a steering angle actuator. The U.S. National Highway Traffic Safety Administration (NHTSA) in 20th November, 2013, issued a recall of 23 Nissan 2014 Infiniti Q50 cars due to the susceptibility of its inherent software, disabling steering in cold temperatures [4]. Though the vehicles were equipped with a backup mechanical steering, existence of such failure from such large manufacturer could increase the latency period for the backup mechanism. In the late 1990's and early 2000's, luxurious models of BMW, Toyota, and Mercedes Benz were equipped with the first DBW technology, TBW control system, that hence improving vehicle handling performance especially in respect to stability and traction control [5].

Anti-Collision System (ACS) design uses a stereo multi-purpose camera to acquire dimensional data of the vehicle and its environment, then detects obstacles with an ultrasonic sensor, then sends signals to an automated emergency braking system that breaks the vehicle at an appropriate condition [6]. Similar to this, Honda Advanced Safety Vehicles (ASV-3) are installed with an Oncoming Vehicle Information Assistance System to interchange its locus data with other equipped vehicles using Inter-Vehicle Communication technology, a system equipped with cameras and radar that sends data of real-time road status (obstacles and vehicles) to drivers and also a system that provides steer and brake assist to the driver [7].

Sensors, actuators, microcontrollers, communication protocols and management system in electric vehicle are key units for fault detection, monitoring, tolerant and control [5]. Therefore several works have been undertaken, to ensure system reliability and safety in case of on board and road fault take place. Nissan fault tolerant approach for their SBW control system discussed above is by multiple monitoring and clutch, it comprises of three electronic control units (ECUs), with each monitoring the other to ensure immediate response from the driver's input which in the case of a fault, switches to a clutch that mechanically links the steering wheel and tires. Majority of stance in ensuring the safety of a microcontroller has been in the exchanging of data between subsystems and having a supervising controller, just as in most EV's the TBW shares information with the yaw stability control/anti-lock brake/traction control microprocessors and a monitoring microprocessor [5]. Hardware redundancy can assist in the fault tolerance of sensors and actuators though different levels of system integrity, depend on design. [3] Proposed a triple redundant master-slave smart actuation unit (SMU) consisting of actuators, controllers, sensors, fault detection and isolation (FDI) and power amplifier ...etc. Each SMU can provide the essential steering function independently. [8], [9] and [10] implemented majority voting

structure for fault detection, isolation and accommodation algorithm (FDIA). In [8], FDIA logic of three sensors, each selected sensor's value is subtracted separately with the values of the other two sensors to compare the result with a selected tolerance, if both values after comparison are true or false the fault state of the selected sensor is reported. A single error in a triple redundant system with majority voting can be masked as the other two values are correct, this is only true for $(N-1)/2$ faults in an N (odd number) redundant system [8]. Most of the encountered problems in the drive-by-wire technology after testing and validation have been as a result of electromagnetic interference (EMI) and the vehicles exposure to high temperature and humidity variations which asserts to be unfavourable for any signal or electronic device [11]. This issue can be addressed by the choice of an appropriate and reliable communication protocol, such as the Controller Area Network (CAN), a serial communication protocol that is used mostly with a Local Interconnect Network (LIN). It was developed for the automobile industry by Bosch - German in 1983, to allow a number of electronic units on a vehicle to share essential control data [11]. Another of such communication protocol that offer real-time and dependable data is the FlexRay though costly, others are the time-triggered protocol, the vehicle area network ...etc.

3. Fault Monitoring, Tolerance and Anti-Collision System Architecture

The fault monitoring, tolerance and anti-collision system architecture is shown in Figure 1. The adopted fault scheme for this work is the use of a fault-tolerant (CAN) bus as proposed by [3].

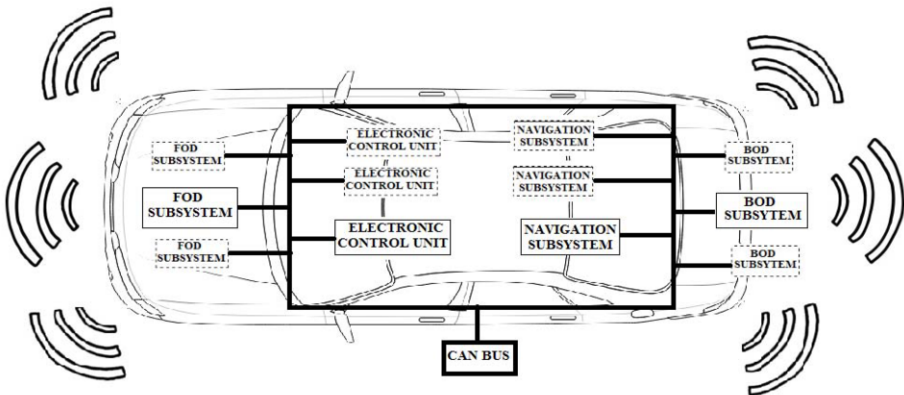

Figure 1: Fault Monitoring, Tolerance and Anti-Collision System Architecture for EV applications

The front and backend obstacles detection (FOD and BOD) unit arrangement are to detect obstacles and communicate the relevant information to the centre control unit. The subsystems enclosed in dotted blocks are the redundant systems which the active subsystem switches, to in the case of a fault. The system approach and architecture is mainly aiming to improve the entire control system robustness in case of obstacles detection, subsystem faults, minimise the risk and increase the safety aspect in electric vehicle technology.

4. Anti-Collision System Working Principles

The Anti-Collision System consists of four subsystems: an electronic control unit (ECU), navigation (NV) unit, and front and backend obstacle detection (FOD and BOD) unit. SRF05 ultrasonic sensors and mbed LPC 1768 microcontrollers were used in the design. In the automobile forward or backward movement, the FOD or BOD subsystem send signals to the ECU of any object ranging within its coverage area. As per the predetermined conditions programmed into the ECU, when the object is at a safe distance from the vehicle, the driver's desired speed is maintained. However below this distance and within the warning range, the LED (amber) alerts the driver of the vehicle's proximity to an obstacle. If the warning range is exceeded, the speed of the vehicle is reduced via the NV subsystem with a flashing red LED, at a distance referred to as the auto-speed reduction (ASR) distance. Beyond the ASR distance, the vehicle stops with the aid of the NV subsystem and the red LED remains steady, the vehicle only moves when the obstacle is out of this distance referred to as the braking point (BP) distance. This concept is similar to the adaptive auto cruise system that maintains a vehicle speed and when appropriate automatically brakes the vehicle using the ISO standard of up to a maximum deceleration of 0.3g [12].

5. Anti-Collision System Development and Prototyping

The design and development of the actual Anti-Collision system has passed through three stages: design, simulation and prototyping. Two identical sensors boards have been manufactured for the front and backend bumpers of the vehicle. These parts were designed with the provision to integrate the ultrasonic sensor through an insulator bolted to the aluminium bumper existing frame opening. This is to prevent interference during ranging. The two boards were integrated into the vehicle and some indoor testing have been carried out. Figure 2 (a) shows the Sensors arrangement for Frond and Backend of the Vehicle. Figure 2 (b) shows the Anti-Collision system integrated into Prototype Vehicle with its road wheel Status on PC.

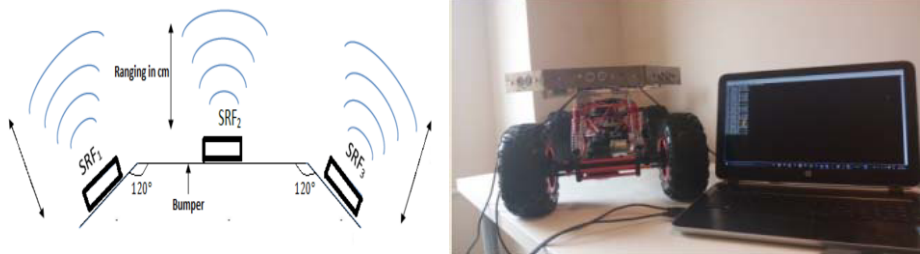

Figure 2: (a). Sensors arrangement for Frond and Backend of the Vehicle (b). Host Vehicle of the Anti-Collision system with Status Display on PC

6. Anti-Collision System Experimental Test and Validation

The four active subsystems were integrated into the prototype vehicle, using the setup shown in Figure 1. A switch words and received values were used to encode and decode data sent in-between subsystems. The Pulse Width Modulation (PWM) signal

from the Electronic Speed Controller (ESC) used for this test has a frequency of 100Hz and a duty cycle between 30% and 50%. During calibration, it was observed that from 0.3 to 0.4 (mid-point or halt value), the forward speed of the vehicle is reduced, while from 0.5 to the mid-point, the backward speed is reduced. During testing, each of the three SRF05 (i, j and k) responded to the presence of obstacles but most importantly, there is an override of command when an SRF05 has an obstacle within its critical zone. For instance, an obstacle at a distance 30cm from i, 20cm from j, and 10cm from k, the instruction routine for the condition of k takes effect on the ACS, hence ensuring critical conditions are prioritized to avoid collision. Also, the vehicle at a distance greater than 100cm from an obstacle still maintained the normal operating speed with a green LED indicating such condition at the ECU. At a distance more than 70cm but less than 99cm from the obstacle, same speed was maintained as the initial condition but only the amber LED was indicating status. At a distance greater than 30cm but less than 69cm, the vehicle speed dropped while a flashing (per 0.3 seconds) red LED replaced the amber. However, as the obstacle was less than 29cm, the previous flashing red LED became steady, with the vehicle at a halt. This condition remained until the obstacle was moved farther from that range (0-29cm), then it started moving without any need for a command by the driver, as all other conditions were running in the background at the vehicle's halt. The indication of obstacles proximity at the opposite direction of the vehicle's movement was displayed but did not affect the speed of the vehicle. These tests findings are shown in Table 1. Visual alerts using LEDs were developed to indicate vehicles or obstacles along the path of the host vehicle even at an opposite direction. It is important to mention that these tests and measurements conducted in a mini prototype vehicle indoor environment. It is also planned that with the filed trial of a real actual car that the measurements could be taken in other reliable and applicable units considering the road standard, safety and traffic agency regulations.

Table 1: Experimental Tests Results of the anti-collision system Indoor Testing

S/N	DISTANCE (cm)	CONDITION	LED	SWITCH_WORD (Hex-Dec)	PWM FWD REV	MOTOR SPEED
1.	>100	Safe	Green	0x01	0.30 0.50	Normal
2.	>70 & <99	Warning	Amber	0x02	0.30 0.50	Normal
3.	>30 & <69	Auto-Speed Reduction	Red (Flash)	0x03	0.35 0.45	Reduced
4.	<29	Braking Point	Red (Steady)	0x04	0.40 0.40	Stop

7. Conclusion and Future Work

The initial outcomes of the undertaken research to develop an intelligent online fault monitoring and anti-collision system for electric vehicle industrial applications have

been presented in this paper. The paper has focused on design and development of the anti-collision system. A prototype of the system has been fabricated, with a network of four near real time embedded subsystems. Visual alerts using LEDs were developed to indicate vehicles or obstacles along the path of the host vehicle even at an opposite direction. Four operational conditions were considered including: safe, warning, auto-speed reduction and halt. Some activities have been taken to control the speed and steering control system of the vehicle at an imminent collision. The system was successfully tested indoor using off-shelf mini vehicle model and further field test have been planned to ensure the operability of the system in relevant applications. Research is still undertaken to develop the online fault detection, monitoring and online recovery tolerance system using the multi-level of redundancy and a hot-standby dual control unit.

References

- [1] A. Altby and D. Majdandzic, *Design and Implementation of a Fault-tolerant Drive-by-wire System*, Masters Thesis, Chalmers University of Technology Gothenburg, 2014.
- [2] C. Wilwert, N. Navet, Y. Song and F. Simonot-Lion, Design of automotive X-by-wire systems, *The Industrial Communication Technology Handbook 1* (2005), 3.
- [3] T. Mei, M. Shafik, R. Lewis, H. Walilay, M. Whitley and D. Baker, Fault tolerant actuation for steer-by-wire applications, *Automotive Electronics, 3rd Institution of Engineering and Technology Conference*, 2007.
- [4] | Safercar | National Highway Traffic Safety Administration (NHTSA), *Www-odi.nhtsa.dot.gov*, 2016, [Online]. Available: http://www-odi.nhtsa.dot.gov/owners/SearchResults?searchType=ID&targetCategory=R&searchCriteria.nhtsa_ids=13V588000&refurl=rss. [Accessed: 11- Mar- 2016]
- [5] S. Anwar, *Fault Tolerant Drive by Wire Systems: Impact On Vehicle Safety and Reliability*, 1st ed., Bentham Science Publishers, Dubai, United Arab Emirates, 2012.
- [6] P. Niveditha and S. Gowri, Collision warning system using ultrasonic sensors and automatic brake system, In *Proceedings of the 5th International Conference on Recent Trends in Information, Telecommunication and Computing*, 419-424, 2014.
- [7] Honda Worldwide | ASV | ASV-3, *World.honda.com*, 2016. [Online]. Available: <http://world.honda.com/ASV/ASV-3/index.html>. [Accessed: 29- Mar- 2016]
- [8] S. Anwar, *Fault Detection, Isolation, and Control of Drive by Wire Systems*, 1st ed., INTECH Open Access Publisher, 2010.
- [9] M. Hasan, *Sliding Mode Observer and Long Range Predictive Based Fault Tolerant Control of a Steer-By-Wire Equipped Vehicle*, Masters Thesis, Indiana University Purdue University Indianapolis, 2007.
- [10] W. Niu, *Fault Tolerant Control of a Steer by Wire System Using Nonlinear Observer and Predictive Method On Hardware in Loop Bench*, Masters Thesis, Indiana University Purdue University Indianapolis, 2009.
- [11] R. Toulson and T. Wilmshurst, *Fast and effective embedded systems design: applying the ARM Mbed*, Elsevier, Kidlington, Oxford, 2012.
- [12] C. Grover, Knight, I. Okoro, F. Simmons, I. Couper, G. Messie and P. Smith, Automated emergency brake systems: technical requirements, costs and benefits (TRL Published Project Report PPR 227), *Crowthorne: Transportation Research Library* http://ec.europa.eu/enterprise/sectors/automotive/files/projects/report_aebs_en.pdf, 2008.